

Badu[®] Stream II

Counter Swimming Unit

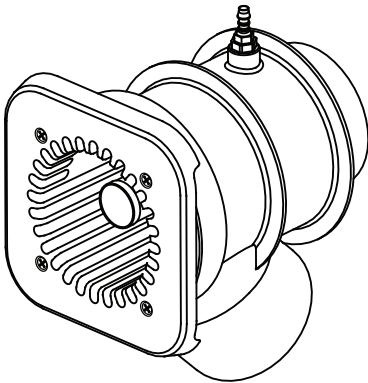

Technical Support:

Address: Speck Pumps
8125 Bayberry Road
Jacksonville, FL. 32256
USA

Hours: (Monday - Friday) 8:00 am to 5:00 pm EST

Toll Free: 800-223-8538

Phone: 904-739-2626

Fax: 904-737-5261

Website: usa.speck-pumps.com

Email: technical.usa@speck-pumps.com

Date of Installation:	
Installed by:	
Serial Number:	
For Service Call:	

Manufactured by Speck Pumps, Jacksonville Florida USA, ©2023 All Rights Reserved.

This document is subject to change without notice.

Table of Contents

1	<i>Important Safety Instructions</i>	4
	SwimJet Combination Fitting Manufacturers Warnings.	4
	General Safety Instructions.	5
<hr/>		
2	<i>General Description</i>	7
<hr/>		
3	<i>Installation Information</i>	7
	Receiving Information	7
	Plumbing Installation	8
	Concrete or Gunite Installation	13
	Liner and/or Fiberglass Pool Installation	15
	Removal of Liner	16
	Electrical - SPECK Controller Installation	17
<hr/>		
4	<i>Service and Maintenance</i>	21
	Nozzle Adjustments	21
	Winterizing	21
<hr/>		
5	<i>Frequently Asked Questions</i>	22
	Frequently Asked Questions	22
	Troubleshooting	23
<hr/>		
6	<i>Product Specification</i>	25
	Replacement Parts and Exploded View	25
<hr/>		
7	<i>Product Information</i>	27
	Product Registration	27
	Limited Warranty	27

Badu® Stream // Certifications



Complies with UL 1563
 CSA C22.2 No. 218.1-M89
 Swimming Pool Equipment
 Listing #E212148



VGBA 2017

1 Important Safety Instructions

WARNING: Before installing this product, read and follow all warning notices and instructions which are included. Failure to follow safety warnings and instructions can result in severe injury, death, or property damage. Call (800) 223-8538 or visit www.usa.speck-pumps.com for additional copies of these instructions.

Swim Jet Combination Fitting - Manufacturers Warnings

MUST BE INSTALLED by an experienced and qualified pool industry professional **ONLY**.

Attention Installer: This manual contains important information about installation, operation, and safe use of this product. This information should be given to the owner and/or operator of this equipment. Most states and local codes regulate the construction, installation and operation of pools and spas. It is important to comply with these codes, many which regulate the installation and use of this product.

1. **DO NOT** locate this fitting in seating areas or on the back rests for such seating areas.
2. This fitting should be mounted in the vertical pool wall only per manufacturer's instructions. No modifications to the swimjet are permitted.
3. The anti-entrapment cover, when installed, shall not protrude more than 2 in. (51mm) from the finished surface of the pool in which the swimjet is installed.
4. **Service Access:** The use of adhesives or other attachment methods that prevent access to suction piping or swimjet components is **prohibited**.
5. The anti-entrapment cover must be hand-checked for snugness to the jet housing after installation.
6. The anti-entrapment cover and fasteners shall be examined for damage or tampering each operational day.
7. Any missing, broken, or cracked fittings must be replaced before using this product. Only genuine Speck replacement parts may be used.
8. Acceptable fittings/pipe sizes are listed on page 8 of this manual. No other sizes are permitted.
9. Never exceed the maximum flow rate stated on this product.
10. The anti-entrapment cover must be in place when using this product. **DO NOT** use this product if the cover is missing, broken, or loose, and it shall be replaced before bathers are allowed to use the pool.
11. The anti-entrapment cover (part# 8) should be replaced within 10 years from installation date.
12. Installation requires a Phillips screw driver. Hand tighten only. **DO NOT** use electrical or air drills.
13. Consult your physician before exercising with the Badu®Stream II or using the massage hose.
14. **DO NOT** permit children to use this product unless they are closely supervised at all times.
15. **DO NOT** remove any safety alert labels such as **DANGER, WARNING, or CAUTION**. Keep safety alert labels in good condition and replace missing or damaged labels.

Swim Jet Combination Fitting - Manufacturers Warnings - continued

16. Stay alert, watch what you are doing and use common sense. **DO NOT** use unit if you are tired and/or exhausted. **DO NOT** use unit while under the influence of drugs, alcohol, or any medications.

CAUTION: DO NOT increase pump size; this will increase the flow rate through the system and exceed the maximum flow rate stated on this product.

IMPROPER INSTALLATION OR USE OF THIS PRODUCT MAY PRESENT A RISK OF HAIR OR BODY ENTRAPMENT AND DROWNING. Install this equipment in accordance with the instructions provided.

As the manufacturer, Speck Pumps-Pool Products, Inc., hereby certifies that their Swim Jet Combination Fitting meets or exceeds the requirements of the Virginia Graeme Baker Pool & Spa Safety Act, VGBA 2017 and ANSI/APSP 16 standards and safety regulations as set forth by the Consumer Products Safety Commission.

“Read, and then keep these instructions for future reference”

General Safety Instructions

The following guidelines provide information to minimize the risk of injury to users of pools, spas, and hot tubs.

WARNING: TO REDUCE THE RISK OF ENTRAPMENT HAZARD



Pool and spa pumps produce high levels of suction, which can pose extreme danger if a person comes in close proximity to an open pool or spa drain or if a drain cover is loose, cracked, broken or missing. Pool and spa pumps move large volumes of water, which can pose extreme danger if a person's hair comes in close proximity to a drain that is not the proper size for the pump or pumps.

If not an approved single, unblockable outlet, a minimum of two functioning suction outlets per pump must be installed. Suction outlets in the same plane (i.e. floor or wall) must be installed a minimum of three (3) feet (1 meter) apart, as measured from center point to center point. Dual suction fittings shall not be located on seating areas or on the backrest for such seating areas. If any suction outlets are located closer they shall be located on two different planes (i.e. one on the bottom and one on the vertical wall, or one each on two separate vertical walls).

WARNING: Failure to keep suction outlet components clear of debris, such as leaves, dirt, hair, paper and other material can result in an increased potential for suction entrapment.

If not a single, unblockable outlet, in the event of one suction outlet being completely blocked, the remaining suction outlets serving the system shall have a flow rating capable of the full flow of the pump(s) or the specific suction system. If in doubt about the rating and/or head loss curve of your system, consult a qualified pool or spa professional and/or your respective equipment manufacturer(s). Also, double check with your local building/health authorities regarding single vs. multiple drain installations, etc.

Regularly inspect all drain covers for cracks, damage and advanced weathering. If a drain cover becomes loose, cracked, damaged, broken or is missing, close the pool or spa immediately, post a notice and keep the pool or spa closed until an appropriate VGBA 2017 certified drain cover is properly installed.

General Safety Instructions - continued

WATER VELOCITY AND FLOW RATES

The maximum water velocity through drain covers is limited by some local regulations, for example some state health departments limit the velocity through public pool drain covers to 1.5 feet per second. This velocity limit is lower than the flow rating provided by the ANSI/APSP 16 certification; therefore local limit applies and must be followed. Never exceed the flow rating listed on the cover even if local code does not provide a velocity limit.

For additional information on proper installation refer to The Association of Pool & Spa Professionals ANSI/APSP-7 Standard and the US Consumer Product Safety Commission Guidelines for Entrapment Hazard.

VGB Compliance - VIRGINIA GRAEME BAKER POOL AND SPA SAFETY ACT

The Virginia Graeme Baker Pool and Spa Safety Act raises certain new requirements on owners and operators of swimming pools and spas.

Pools or spas constructed on or after December 19, 2008, shall utilize:

- (A) No submerged suction outlets, a gravity drainage system with ANSI/APSP compliant cover(s), one or more unblockable outlets; or
- (B) A multiple main drain system without isolation capability with suction outlet covers that meet ANSI/APSP 16 Suction Fittings for Use in Swimming Pools, Wading Pools, Spas, and Hot Tubs and either:
 - (i) A safety vacuum release system (SVRS) meeting ASME/ANSI A112.19.17 Manufactured Safety Vacuum Release Systems (SVRS) for Residential and Commercial Swimming Pool, Spa, Hot Tub, and Wading Pool Suction Systems and/or ASTM F2387 Standard Specification for Manufactured Safety Vacuum Release Systems (SVRS) for Swimming Pools, Spas and Hot Tubs or
 - (ii) A properly designed and tested suction-limiting vent system or
 - (iii) An automatic pump shut-off system.

Pools and spas constructed prior to December 19, 2008, with a single submerged suction outlet shall use a suction outlet cover that meets ANSI/APSP 16 and either:

- (A) A multiple main drain system without isolation capability, or a single (VGBA 2017 compliant) unblockable suction outlet, or
- (B) A safety vacuum release system (SVRS) meeting ASME/ANSI A112.19.17 and/or ASTM F2387, or
- (C) A properly designed and tested suction-limiting vent system, or
- (D) An automatic pump shut-off system, or
- (E) Disabled submerged outlets, or
- (F) Suction outlets shall be reconfigured into return inlets.

For more information about the Virginia Graeme Baker Pool and Spa Safety Act, contact the Consumer Product Safety Commission at (301) 504-7908 or visit www.cpsc.gov.

WARNING: Risk of Electrical Shock or Electrocution

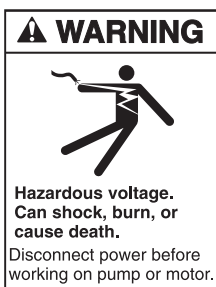

Pool pump must be installed by a licensed or certified electrician or a qualified pool serviceman in accordance with the National Electrical Code and all applicable local codes and ordinances. Improper installation will create an electric hazard which could result in death or serious injury to pool users, installers, or others due to electrical shock, and may also cause damage to property.

Always disconnect power to the pool pump at the circuit breaker before servicing the pump. Failure to do so could result in death or serious injury to serviceman, pool users, or others due to electric shock.

2 General Description

General Description

The BaduStream // SwimJet Systems from Speck Pumps are designed to be installed during the construction of your pool to create a water treadmill for anyone wanting a therapeutic and effective exercise.

The BaduStream // can be installed in any type of pool, large or small, from gunite to vinyl liner. It has no protruding parts ensuring pool user's safety, is very compact and installs at minimal cost. The self-contained, flush-mounted unit is a jet-propulsion system that pumps water into the pool creating a current in excess of 5,700 gallons per minute from a single recessed jet housing. Topping off the experience is the pulsating massage hose which can be attached to the jet nozzles for easy and convenient massage treatments for joints and muscles. (NOTE: The massage hose is sold separately.)

3 Installation Information

Planning

The BaduStream II is normally incorporated into the original pool design. However, it can be added to any pool at a later date. The BaduStream II has no protruding parts, ensuring the pool user's safety. It is very compact and installs at minimal cost. The system can be installed in any size pool.

We suggest a minimum pool size of 8 ft wide x 15 ft long x 3 ft deep to work effectively. Most prefer 16 ft. in length or longer. The extra length allows enough length for a swimmer to comfortably drift back and swim up stream.

To ensure that there is a clear unobstructed swim lane, it is key to position the swimjets away from surroundings walls, benches, stairs, etc. Obstructions near the swimjets can disrupt the current.

- 1 Ideal Locations*
- 2 Alternative Locations*
- || Unfavorable Locations

Here are a few examples:

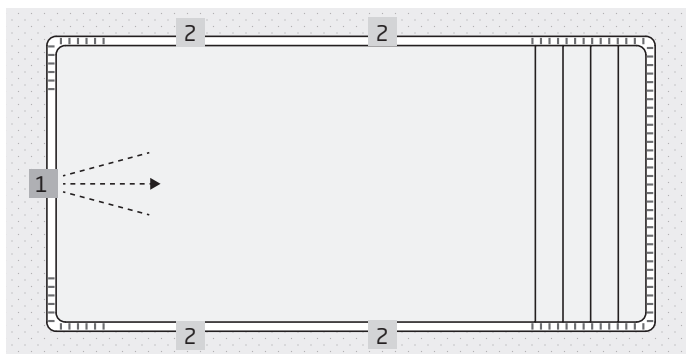
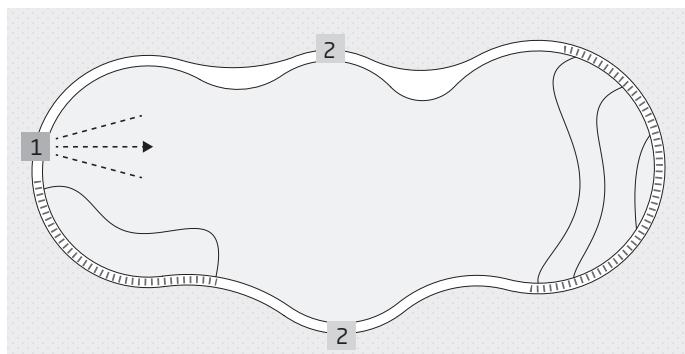
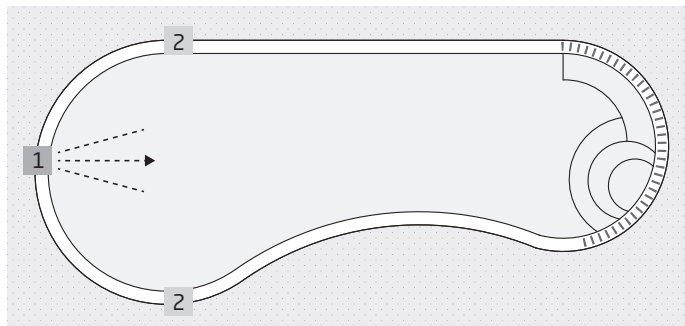

*Reminder: BADU SwimJet Systems require a clear **unobstructed** area within the swimming pool that is 8 feet wide x 15 feet long x 3 feet deep to work effectively. This "swimming envelope" allows enough length for a swimmer to comfortably drift back and swim up stream.

Receiving Information

1. Upon receipt of the swimjet system, check the cartons for damage. Open each carton and check the pump(s), jet housing(s), and control box for concealed damage, such as cracks, dents, or a bent base. If damage is found, contact the shipper or distributor where the swimjet was purchased.

2. Inspect the contents of each carton and verify that all parts are included. (See Image 1)

- A. Flush-mount jet housing
- B. Square, anti-entrapment cover (8¹/₄" x 8¹/₄" undetectable pump suction. (Optional Round Cover available)
- C. Adjustable water flow jet nozzle
- D. Air regulator adjusts amount of air bubbles in water flow.
- E. Control box complete with GFCI and WiFi control module.
- F. SPECK Model 21-80/33GS 4.0 HP (or a SPECK Model 72-VI 3.5 HP) self-priming, single phase plastic pump with built-in thermal overload (no motor starter required). Optional three phase pump and control box available. (NOTE: Flooded suction pump available for installation below water level.)

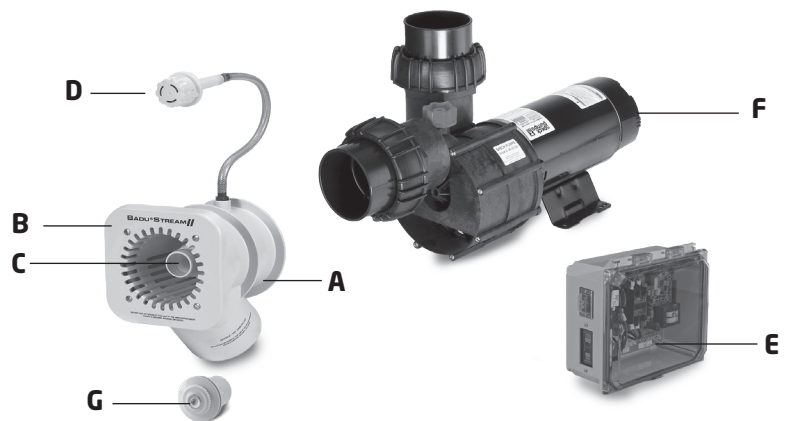

Image 1
BaduStream II System (1 jet & 4 HP pump)

- G. System (ON/OFF) LED Push Button - Complete with 1.5" threaded housing fits into any 1.5" return fitting. The push button turns the swimjet system ON/OFF. Waterproof button may be installed below water level.

Plumbing Installation

CAUTION: The discharge connection is at the center of the back of the jet housing. The suction connection is at the bottom of the jet housing.

CAUTION: The suction line should remain below water level from the suction connection at the jet housing to a point directly beneath the pump.

CAUTION: The center of the BaduStream jet nozzle(s) must be located 12" **BELOW** the water line for maximum performance and efficiency. The air regulator(s) should be located 3-4" **ABOVE** the water line.

CAUTION: In areas with soft soil conditions or with frequent earth movement, a flexible section of 4" hose should be installed at the back of the jet housing to prevent plumbing or jet housing damage.

CAUTION: For trouble-free pump priming (up to 4 feet above the water line), first install a 6" long riser in the discharge connection on top of the pump(s). Then install an elbow and lead the discharge line(s) downward to the discharge connection(s) at the BaduStream jet housing(s) (Not required with 3.5 HP pump Model 72). On systems with 3 jet housings and 2 pumps, check valves **MUST** be installed at the discharge connections at each pump.

CAUTION: Allow at least 12 hours curing and bonding time. Insufficient curing and bonding times can result in leaks and flooding.

CAUTION: Throughout the entire installation, make sure the plumbing connected to the BaduStream jet housing is well supported. Unsupported plumbing **WILL** crack the jet housing.

CAUTION: DO NOT use the pump as a fixed point (support) for the plumbing.

Plumbing Installation

CAUTION: When using 6" pipe, install 6" x 4" reducer bushings as close to the jet housing(s) as possible. For systems with 2 or 3 jet housings, install the 6" x 4" reducer bushings as close to the 4" manifold tees as possible. The 6" suction and discharge lines should be run from the jet housing(s) and remain under the water line to a point directly beneath the pump(s). Install 6" elbows at that point. Then run 4" pipe vertically up to the suction and discharge connections of the pump and finish with a 4" elbow.

- For optimal performance, use 4" plumbing when the total distance between the pump and jet housing is 30 ft or less. The plumbing should be as direct and free from turns or bends as possible because **elbows and other fittings can create large friction losses and reduce the performance of the system. The shortest length of pipe with the minimum number of fittings possible should be used to avoid any significant friction loss due to the pipe and fittings.** NOTE: Refer to Figure 2 for the BaduStream head loss curve.
- A maximum of seven (7) 90° elbows may be used with 30 ft of horizontal 4" pipe for the suction line and 30 ft of horizontal pipe for the discharge line without negatively affecting the performance of the system. NOTE: This applies to each individual pump used on the system. Refer to Figure 4 for the maximum TDH allowed to achieve recommended flow rates.
- If more elbows are required for the installation, 4" sweeps must be used in place of the elbows. When using sweeps instead of elbows, a maximum of nine (9) 4" sweeps may be used with 30 ft of horizontal 4" pipe for the suction line and 30 ft of horizontal 4" pipe for the discharge line without negatively affecting the performance of the system. NOTE: This applies to each individual pump used on the system. Refer to Figure 4 for the maximum TDH allowed to achieve recommended flow rates.
- If the pump(s) cannot be located within 30 ft of the jet housing(s) using the maximum number of 4" elbows or sweeps stated above, then 6" plumbing must be used. For the suction and discharge lines, use 6" plumbing and fittings from the connection at the jet housing (or at the manifolds for two and three jet systems) to a point directly beneath the pump. From that point, install a 6" elbow. Then run 4" pipe vertically up to the suction and discharge connection of the pump and finish with a 4" elbow.
- For two and three jet systems, the jet housings **must be installed as close to 10" center to center as possible for maximum performance. DO NOT install the jet housing more than 12" apart on center.** (See Figure 1 & 1A)

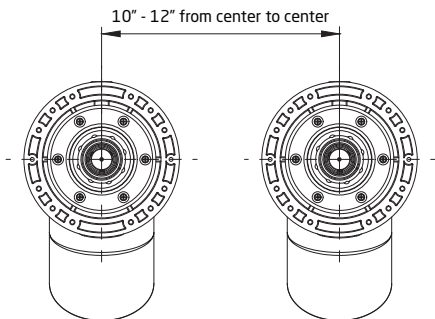

Figure 1
Two Jet (10" - 12" from center to center)

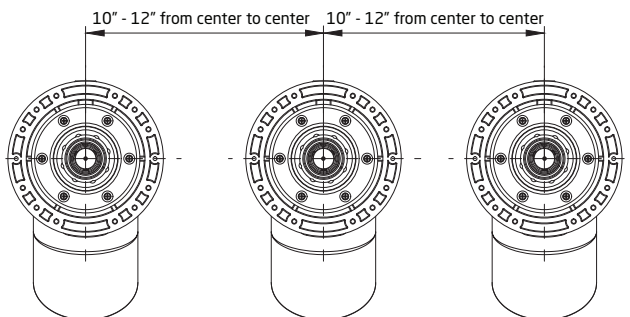

Figure 1A
Three Jet (10" - 12" from center to center)



Plumbing Installation - continued

NOTE: Suction lines which are too long have significant disadvantages:

- Higher resistance which results in less efficient priming and a higher risk of cavitation.
- Longer priming time (up to 12 min).
- Keep the suction and pressure lines as short and straight as possible.
- If the pump is positioned further away, then the pipe dimensioning has to be adapted so that almost loss-free flowing is ensured.

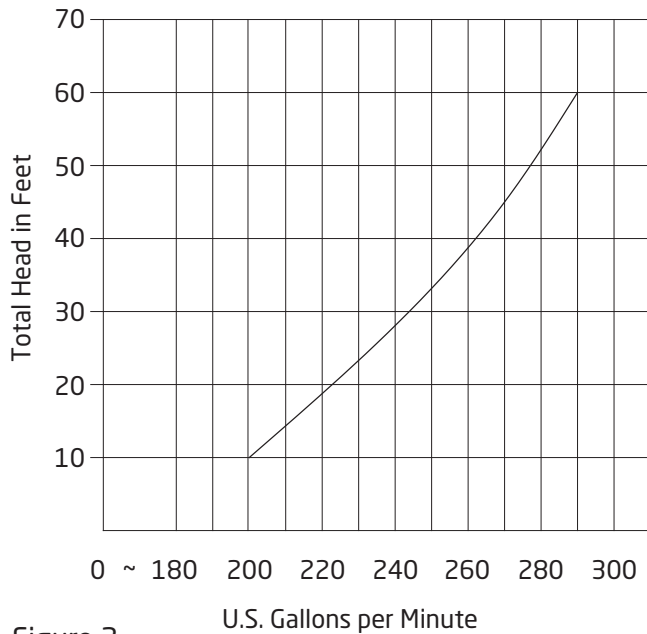

Figure 2
BaduStream II Head Loss Curve (Single Jet Housing)

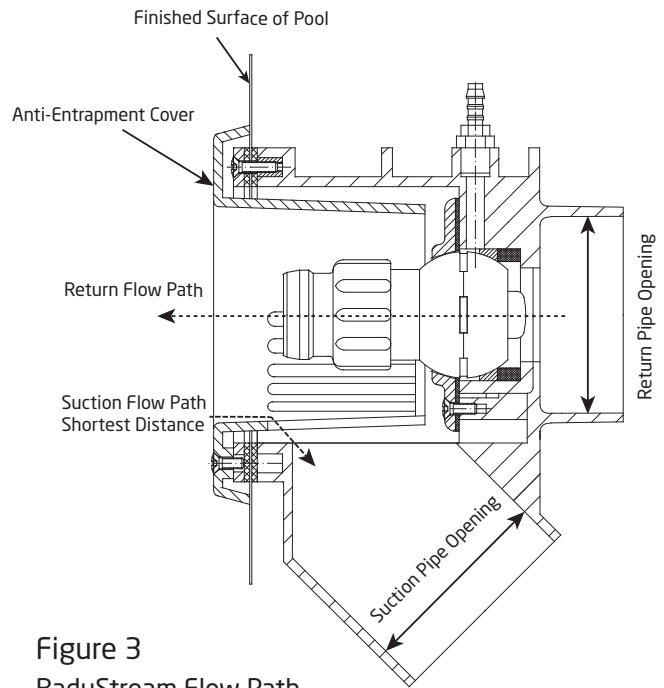

Figure 3
BaduStream Flow Path

NOTE: The BaduStream assembly package contains all necessary parts for the installation of the unit into concrete, gunite, liner or fiberglass pools.

CAUTION: All necessary screws and bolts included with the BaduStream are stainless steel. ALL screw threads and threaded inserts are METRIC! ONLY METRIC bolts and nuts may be used! The two exceptions are the suction and discharge connections on the BaduStream and pump housing (4" slip connections) and the mounting hardware for the air regulator assembly (1/4 -20 threads). All screws should be **HAND TIGHT**. **DO NOT** use drills or pneumatic tools. **DO NOT** over tighten!

Plumbing Requirements

BaduStream II	Pump	Distance	Pipe Size	Approx. Flow	TDH
Three Jets	(2) 4 HP	10 to 30 ft.	4"	651 GPM	42 ft
		up to 50 ft.*	6"	651 GPM	42 ft
Two Jets	4 HP	10 to 30 ft.	4"	380 GPM	34 ft
		up to 50 ft.*	6"	400 GPM	32 ft
One Jet	4 HP	10 to 30 ft.	4"	217 GPM	53 ft
		up to 50 ft.*	6"	217 GPM	53 ft
One Jet	3 HP	10 to 30 ft.	4"	200 GPM	12 ft
		up to 50 ft.*	6"	200 GPM	12 ft

Plumbing Installation - continued

* 6" pipe will allow distances of well over 50 ft. There is 50ft of cable included with the push button. If a longer distance to the control box is required, a junction box can be installed above the water line to splice additional cable as required or you may purchase a 100 ft. button (part# 2336002800B).

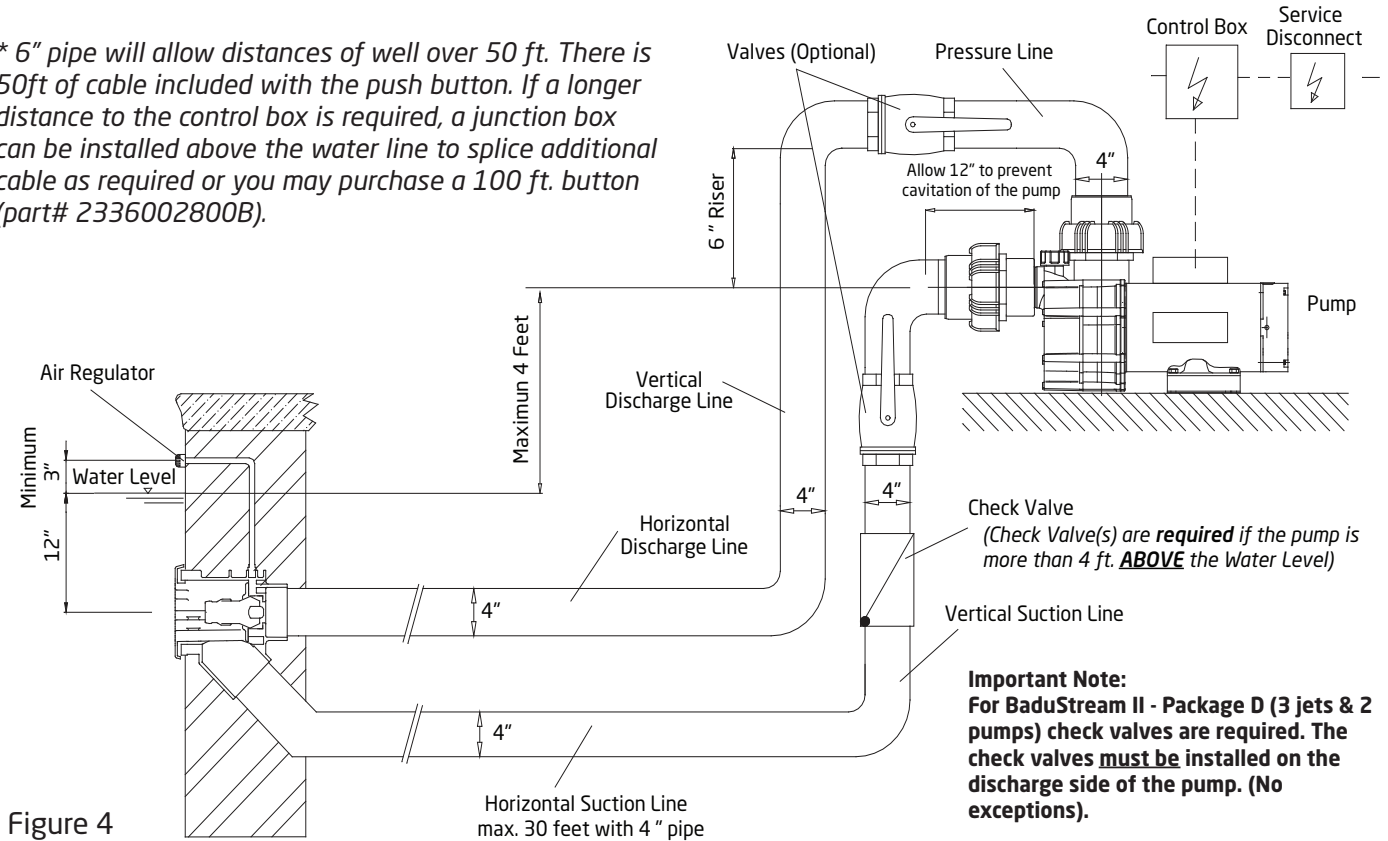

NOTE: Valves are recommended when pump is installed below water level (flooded suction applications).

NOTE: To avoid stress on the jet housing, the jet housing and 2 to 3 inches of plumbing stub out may be encased in gunite or concrete.

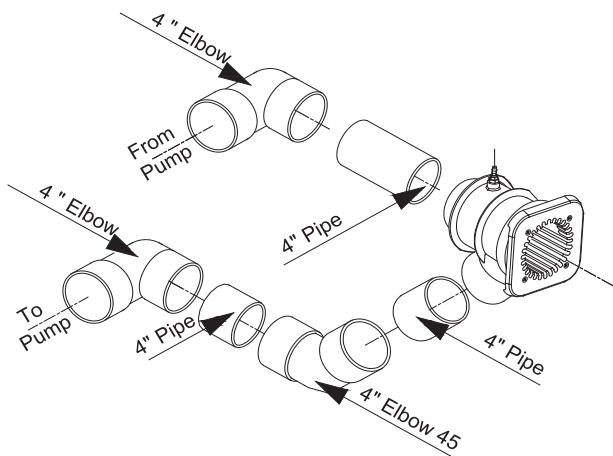

Figure 5
BaduStream **Single** Housing Installation



Plumbing Installation - continued

NOTE: (For **Dual Jet Installation**) Increase the pipe size to 6" when jets are more than 30 ft. from the pump. Use 6" x 4" bushings after 4" manifold tees.

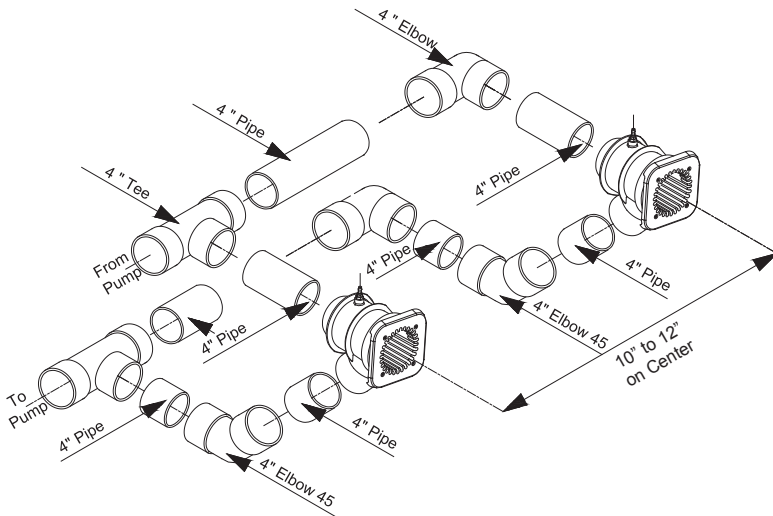

Figure 6
BaduStream **Dual** Housing Installation

Plumbing installation for the BaduStream **Package D** (system include three jet housings & two pumps)

NOTE: (Three Jet Installation) Increase the pipe size to 6" when jets are more than 30 ft. from the pump. Use 6" x 4" bushings after 4" manifold tees.

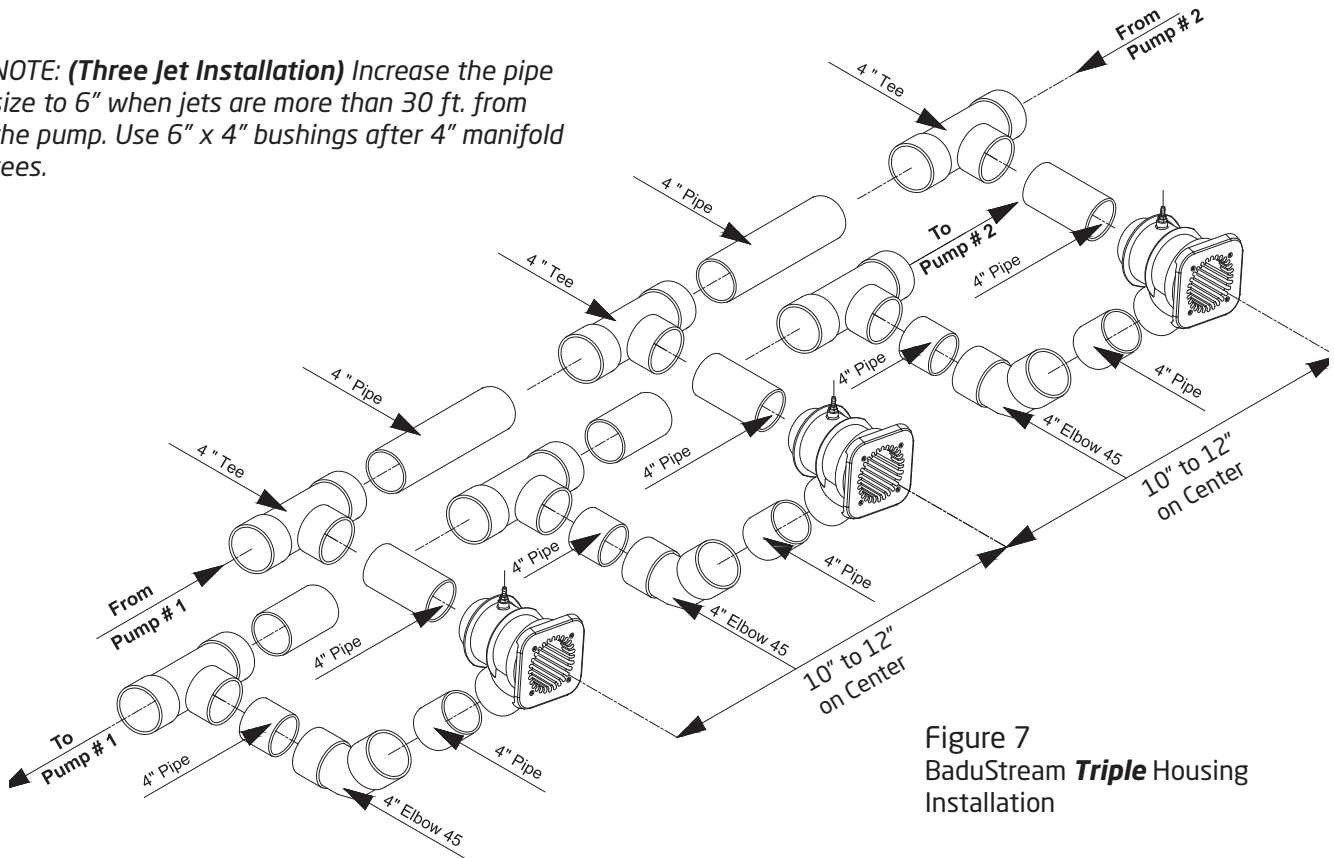

Figure 7
BaduStream **Triple** Housing Installation

IMPORTANT NOTE: CHECK VALVES MUST BE used on the discharge side of each pump. Minimum 4" pipe between pump and BaduStream plumbing manifold.

Plumbing Installation - continued

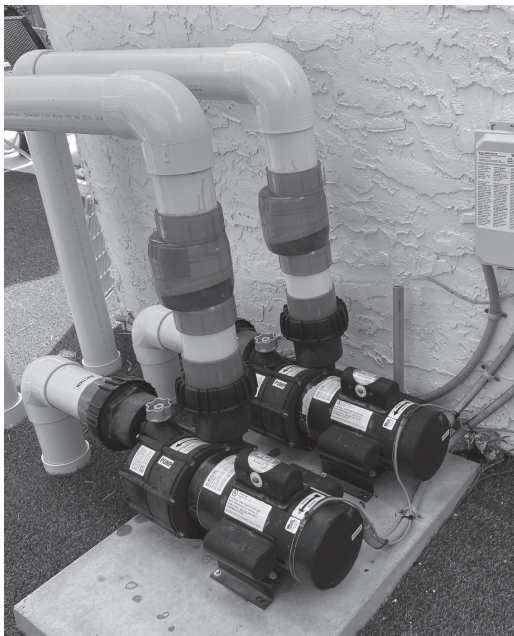

Figure 8
Check Valves Installed for a Package D (three jet & 2 pump system)



Concrete or Gunite Installation

NOTE: The following parts *ARE NOT USED IN A GUNITE or CONCRETE INSTALLATION:*

- Clamping Ring Gasket (Part #12)
- 1/4-20 x 1-1/2" Bolt (Part #18)
- 1/4-20 Nut (Part # 19)
- 1/4" Washer (Part #20)
- Air Regulator Gasket 60 x 11 x 2 mm (Part #21)
- #14 x 1" Screw (Part #27)

1. Pre-plumb BaduStream jet housing(s):

- A. Install plumbing manifold (for two and three jet systems) or approximately 12" of 4" SCH 40 pipe (for single jet systems) to both suction and discharge fittings on the jet housing(s). See Figure 9
- B. Thread one (1) air regulator hose nipple into the top of each jet housing. Secure plastic air regulator hose (part #15) to the air regulator hose nipple(s) (part #14) using the hose clamp(s) (part #16).

2. Tape the jet housing(s) to keep concrete out of threaded inserts and out of the inside of the housing(s). See Figure 10.

3. Place the jet housing(s) between the steel rebar. **Note: The jet housing location is very important.**

- A. Make sure that the air regulator hose nipple (part #14) is at the top and center of each jet housing. **Failure to do so will result in the square cover (part #8) appearing uneven.**

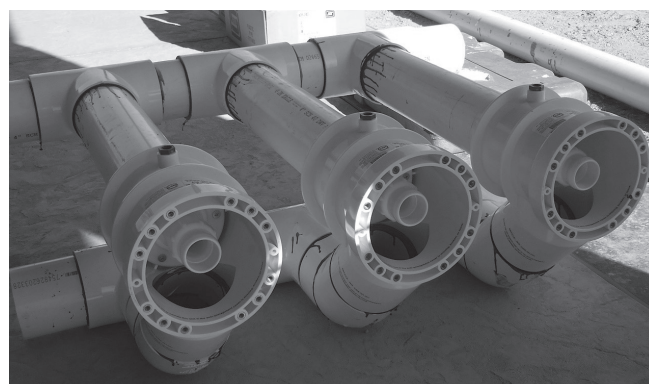

Figure 9
Pre-Plumbed Jet Housings



Figure 10
Taped Jet Housings

Concrete or Gunite Installation

- B. The center of each jet housing (*the nozzle*) must be located **12" BELOW** the water line for maximum performance and efficiency.
- C. Recheck the location of the jet housing while applying gunite or pouring concrete. Make sure the jet housing remains properly aligned and level.
- D. Front edge of each jet housing should finish even with inside finished pool wall. Scrape out a V-shaped groove around the jet housing, approximately 1.5" deep to allow marcite to seal against the jet housing. See *Figure 11*.
- E. To avoid stress on the housing, the jet housing and 2 to 3 inches of plumbing stub out may be encased in gunite or concrete. **CAUTION:** *Too much stress on the plumbing may crack the BaduStream II housing.*
4. Install the air regulator. **NOTE:** *Air regulator location should be 3"- 4" ABOVE the water level.*
- A. Thread one (1) air regulator hose nipple (*part #14*) into the back of the air regulator holder (*part #17*). Connect the free end of the plastic air regulator hose to the nipple on the back of the air regulator holder. Secure with a hose clamp (*part #16*).
- B. The air regulator can be located in the tile above the water level or in the deck. When tiling the pool, adjust the air regulator location so it is 3"-4" **ABOVE** the water level. Place and set with hydraulic cement. The air regulator holder (*part #17*) should finish flush with the inner pool wall. Drill a 1/2" hole in the tile line even with the center hole of the air regulator holder. Tile over the air regulator holder. **CAUTION: DO NOT** *plug the center hole of the air regulator holder.*
- C. Insert the M10 x 80 mm brass screw (*part #24*) through the bottom part of the air regulator (*part #23*), the 42 x 11 x 2 mm and the air regulator gasket (*part #26*). Thread the M10 x 80 mm brass screw into the center of the air regulator holder (*part #17*). Tighten with a flat head screw driver.
- D. Install the hose ring (*part #25*) and snap the top part of the air regulator (*part #22*) into place. See *Figure 12* for air regulator assembly.

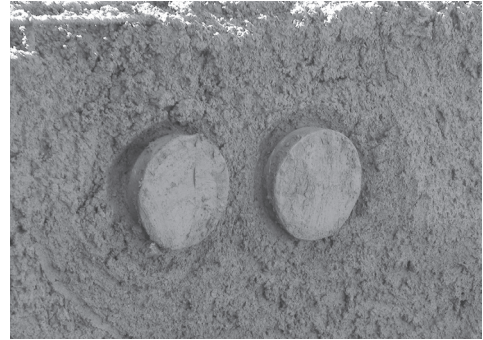

Figure 11
V-Shaped Groove in Gunite

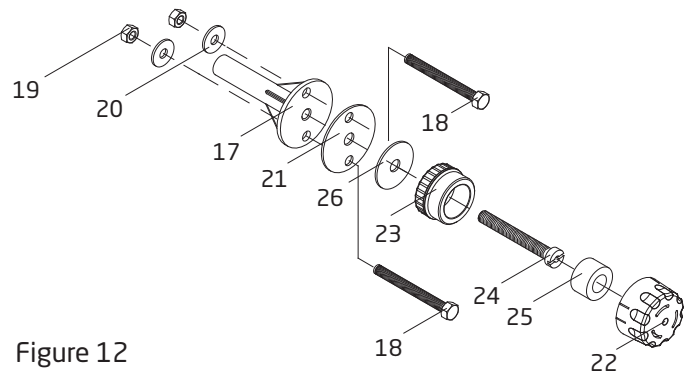

Figure 12
Air Regulator Assembly

5. Keep all parts not being used now in original box. Store in a safe place until needed.

NOTE: *An extension ring and longer square cover screws (part #9/5) are available (upon request) for applications where the housing is recessed into the pool wall.*

6. Once the concrete or gunite is fully cured and pool wall is completed, install the square cover (*part #8*) using the four (4) M6 x 25mm square cover screws (*part #9/1*).

NOTE: *In tile installations, the tile thickness can be compensated for by first installing the clamping ring gasket (part #12) and clamping ring (part #3) before installing the square cover. The clamping ring and clamping ring gasket are installed using the eight (8) clamping ring screws (part #9/2, 9/3, or 9/4).*

Concrete or Gunite Installation - continued

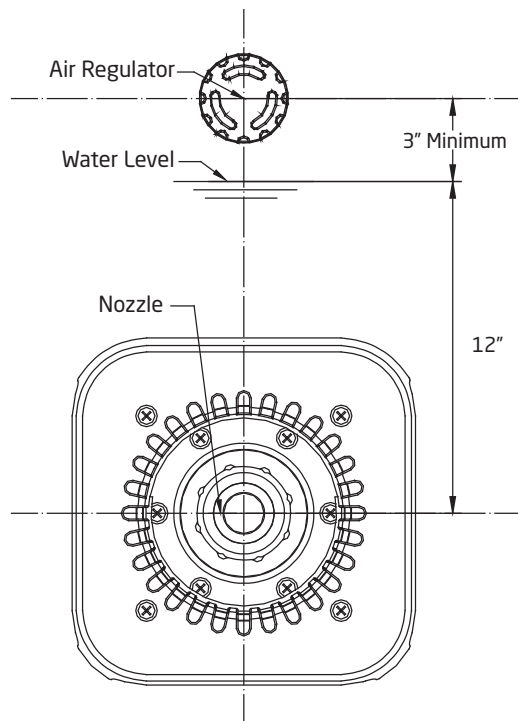

Figure 13
Installation in Concrete or Gunite Pools

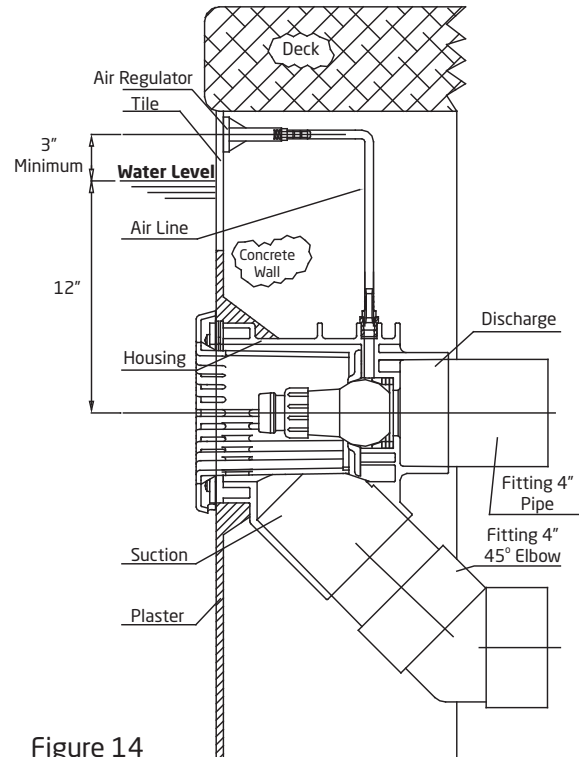

Figure 14
BaduStream in Concrete or Gunite Pool.

Liner and/or Fiberglass Pool Installation

1. Using the clamping ring (part #3) as a template, drill holes in the pool wall for installation. The center line of the clamping ring should be 12" **BELOW** the water level (See Figures 15 & 16). Two additional holes will need to be drilled at the 3 and 9 o'clock positions for installation of the jet housing (part #7). The four brass inserts in the clamping ring should be at the 2, 4, 8 and 10 o'clock positions (See Figure 15).

2. Mount the housing (part #7) and one clamping ring gasket (part #12) on **BEHIND** the pool wall using two (2) #14 x 1" counter sunk screws (part #27). Install the screws from the inside of the pool wall through the holes drilled at 3 and 9 o'clock positions. (See Figure 15)

3. Install the clamping ring (part #3) and a second clamping ring gasket (part #12) in **FRONT** of the pool wall using eight (8) M6 screws (part # 9/2, 9/3, or 9/4). Screw lengths vary depending on the installation. *NOTE: A good RTV silicone may be used with the gasket when mounting the jet housing, but in most cases is not necessary. Installer should decided whether or not the silicone is necessary.*

NOTE: When installed properly, the center of the housing (part #7) will be 12" **BELOW** the surface of the water and the air regulator hose nipple (part #14) will be at the top center of the jet housing.

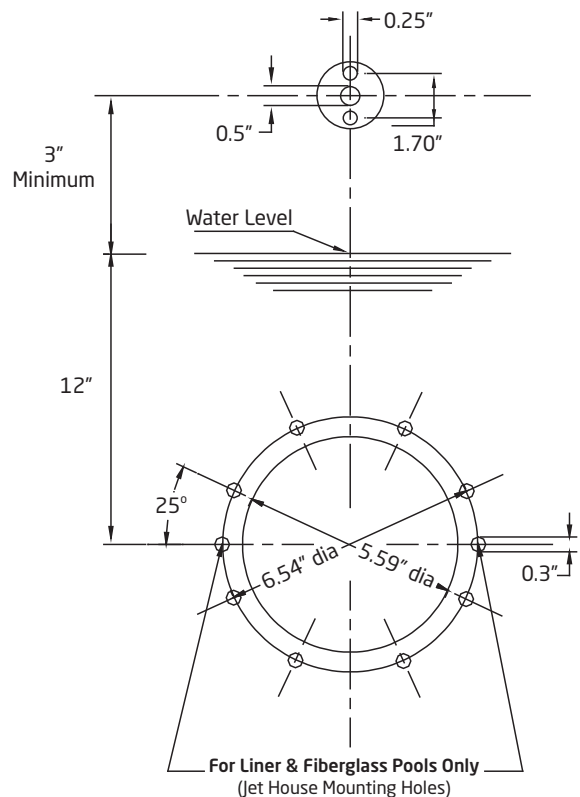

Figure 15
Cutout Pool Wall for BaduStream housing.

Liner and/or Fiberglass Pool Installation - continued

CAUTION: When installing the BaduStream Cover (part #8). Use a Phillips head screw driver and tighten to 1.5 Nm or hand tight. **DO NOT** use electrical or air drills. (NOTE: The square cover, part #8, will have an uneven appearance if the housing is not installed properly.)

4. For the air regulator assembly, one 1/2" hole must be provided, preferably along the vertical axis, approximately 3-4" **ABOVE** the water line. (See Figures 15 & 16). Using the 60 x 11 x 2mm air regulator gasket (part #21), mark and drill two 1/4" mounting holes (See Figure 15). Use the two (2) 1/4 - 20 air holder screws (part #18) and two 1/4-20 air holder nuts (part #19) to mount the air regulator holder.

NOTE: Part #18 & Part #21 go in **FRONT** of the pool wall; Part #19 & Part #17 go **BEHIND** the pool wall.

5. Keep all parts not being used now in original box. Store in a safe place until needed.

6. Once the pool is complete, install the square cover (part #8) using the four (4) square cover screws (part #9/1).

For Liner Pools Only: Install the jet housing and air regulator prior to installation or replacement of the pool liner.

For Steel Walled Pools: An optional butterfly gasket (part #12.1) maybe purchased to replace the two (2) clamping ring gaskets (part #12). Increase the jet housing hole in Figure 15 from 5.59" to 5.75" for installation.

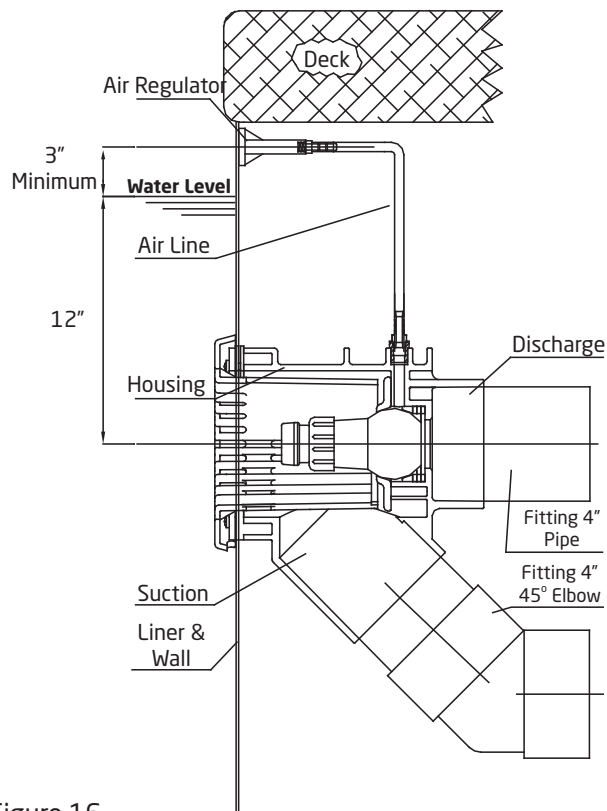

Figure 16
BaduStream in Liner or Fiberglass Pool.

Removal of Liner

When replacing liner or removing liner for repairs; remove the four (4) screws (part #9/1) which hold the square cover (part #8) to the jet housing. Remove all screws (part #9/2, 9/3 & 9/4) except the top two, which hold the clamping ring (part #3) and gasket (part #12) to the jet housing. Back out the two remaining screws approximately halfway and check for any movement of the jet housing from the wall. (NOTE: If the two counter sunk screws (part #27) which hold the jet housing to the wall were installed, the jet housing should not move, and the two remaining screws can be removed.) Remove one of the remaining two screws and slide the clamping ring (part #3) to the side. Replace all the screws before removing the last screw. Remove or replace the liner. Reverse the process to install liner.

NOTE: When replacing the clamping ring and screws: locate screw heads under liner, make a small cut on the liner at the screw heads and push the liner over the screw head.

Electrical - SPECK Controller Installation

WARNING: The wiring of the pool motor and control box should be done by a licensed electrician in accordance with all local, state, and federal codes. Be certain that the motor frame and control box are properly grounded. Motor name plate lists voltage, phase, amp draw, and other information as well as wiring connection instructions.

This section concerns the electric motor and control box for BaduStream II swimjet system.

CAUTION: Before installing the Speck Pump, read the entire pump owner's manual found in the pump box.

Consult local codes for minimum distance between pump and pool. Locate pump as close to the pool as practical.

CAUTION: There is 50ft of cable included with the push button. If a longer distance to the control box is required, a junction box can be installed above the water line to splice additional cable as required or you may purchase a 100 ft. button (part# 2336002800B).

NOTE: The System ON/OFF LED push button is installed in a 1-1/2" threaded housing. This housing may be installed in any 1-1/2" return fitting, either below the water line or above the water.

BONDING: As required by National Electrical Code, the pump motor must be electrically bonded to the pool structure (reinforced bars, etc.) by a solid copper conductor not smaller than No. 8 AWG via the external copper bonding lug on the pump motor.

GROUNDING: Permanently ground the pump motor and control box using a conductor of appropriate size.

- **Pump Motor:** Connect to the #10 green headed ground screw provided inside the motor terminal box.
- **Control Box:** Connect to the aluminum grounding terminal strip on the inside of the control box enclosure.

CAUTION: DO NOT connect to electric power supply until the unit is permanently grounded.

NOTE: Single phase control boxes equipped with GFCI are shown on pages 17-18. Other options are available. Please contact the factory (800) 223-8538 for assistance.

Connecting the SPECK controller to a WiFi network for the FIRST TIME:

1. Before connecting the SPECK controller to the WiFi network, stand where the SPECK equipment is located and with your mobile device in-hand assure that the signal strength to the WiFi network is good to excellent (*weak signals will cause problems*).
2. Make sure the power to the SPECK Device is turned ON. There is a green indicator on the controller board to indicate power. A small "o" will be flashing on the LED display.
3. Give the homeowner the BADUConnect app manual and allow them to finish the App setup. *For more information, Call (800) 223-8538 or visit www.baduconnect.com for additional copies of the BADUConnect App instructions.*

Electrical - SPECK Controller Installation - Continued

Figure 17
Control Box Wiring

Power from main panel (230 VAC):
Neutral, Line 1, Line 2

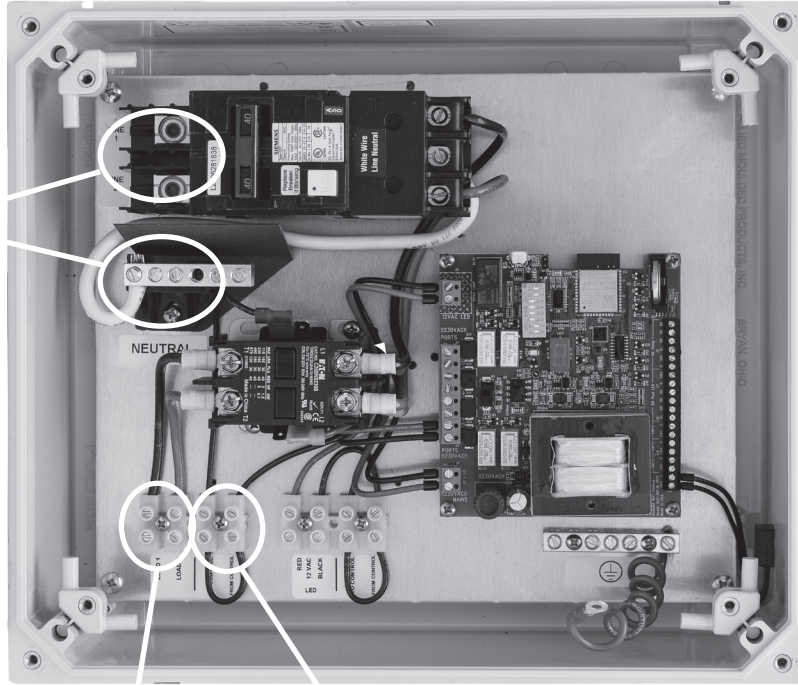

Power to pump motor (230 VAC):
Load 1, Load 2

Connection for remote relay
(Remove Jumper)
Contact MFG for wiring instructions.

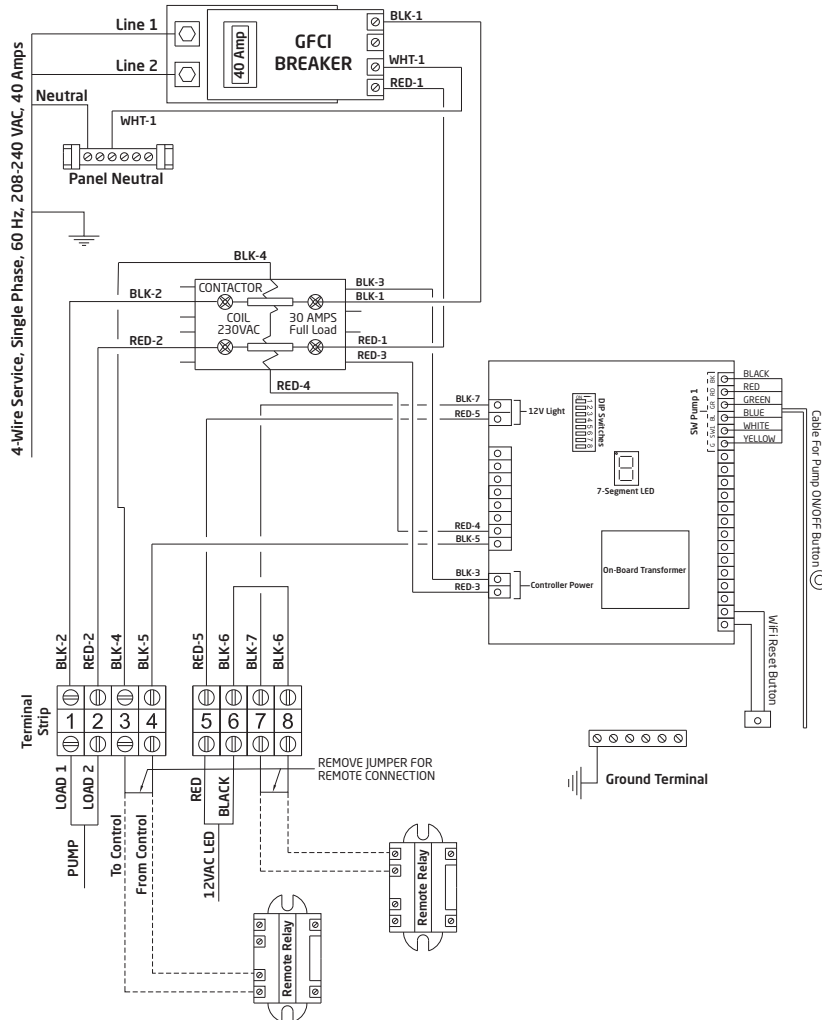

Electrical - SPECK Controller Installation - Continued

Figure 17A
Control Box Wiring

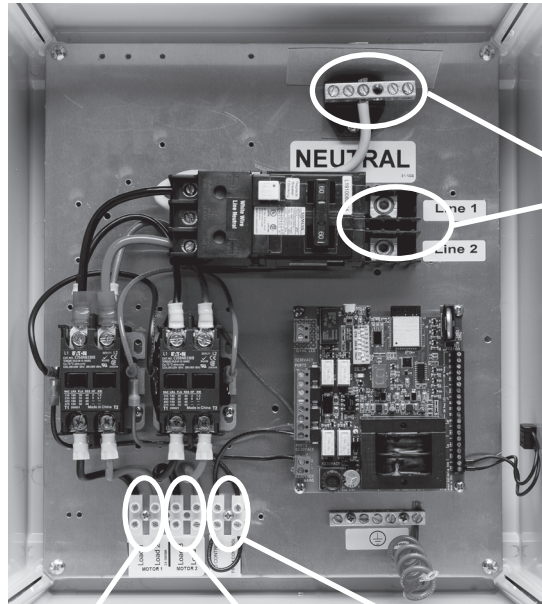

Power from main panel (230 VAC):
Neutral, Line 1, Line 2

Power to pump motor 1
(230 VAC): Load 1, Load 2

Power to pump motor 2
(230 VAC): Load 3, Load 4

Connection to remote relay
(120 VAC)
Contact MFG for wiring instructions.

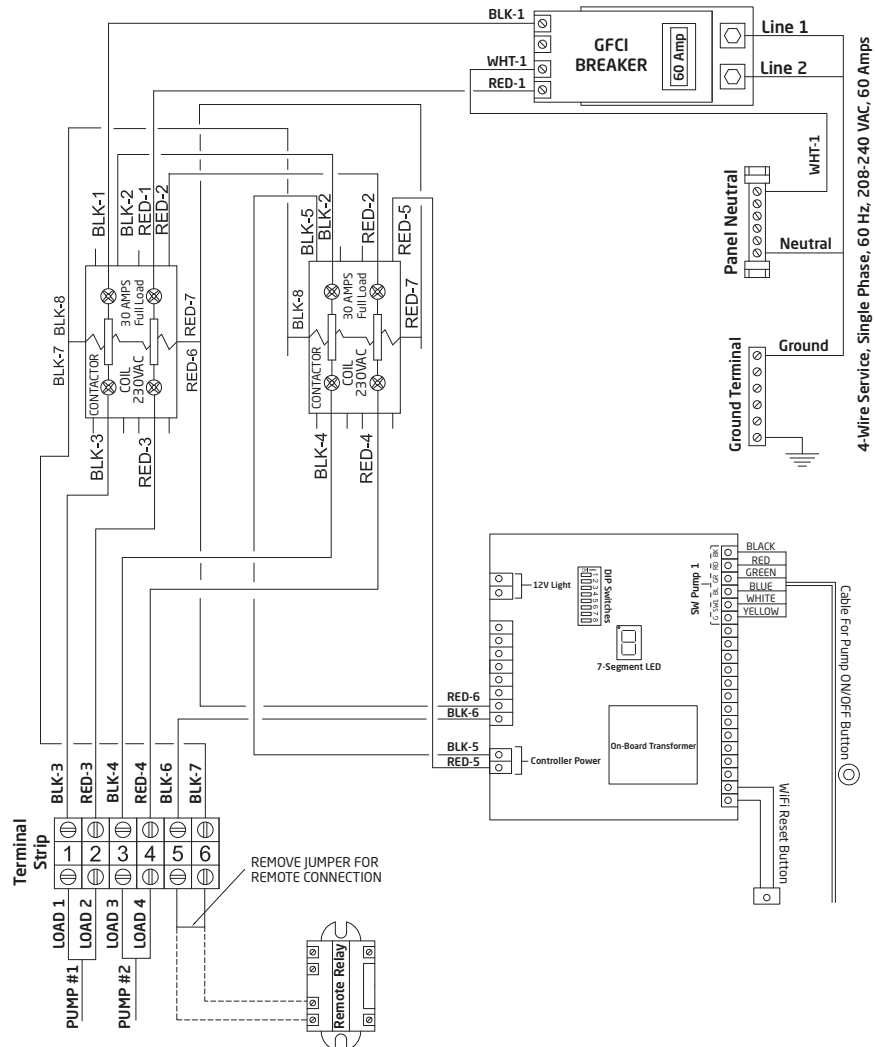

Electrical - SPECK Controller Installation - Continued

Table 1
LED Push Button Color Codes

COLOR	MEANING
Solid BLUE	SwimJet System is OFF
Flashing GREEN every 1 second	SwimJet System is ON with 2 hour timer
Flashing GREEN every 1/2 second	This is a 2 minute warning on the 2 hour timer. Once the 2 minutes have passed the swimjet system will automatically turn OFF.

Table 2
LED Codes & Meanings

PATTERN ON LED DISPLAY	CONDITION
Flashing Dash (-) with an interval of ~200ms	Ideal with no Relay/Pump on
Flashing 'P' with the interval of ~200ms	No WiFi connection, Wrong Wifi Password
Flashing 'O' (Capital O) with an interval of ~200ms	No cloud connection due to server down or no internet
Flashing 'o' (Small o) with an interval of 200ms	Device has not been set up to connect to WiFi
Flashing '≡' (triple bars) with an interval of 200ms	The device is doing OTA Firmware update
Flashing 'E' with an interval of ~200ms	Hardware error
Flashing 'L' with an interval of ~200ms	Pool light error
Steady 2	Port 2 is on manually (No Timer/Schedule)
Steady 3	Port 3 is on manually (No Timer/Schedule)
Steady 4	Port 4 is on manually (No Timer/Schedule)
Steady 5	Port 5 is on manually (No Timer/Schedule)
Steady 1 with flashing dot. The dot will flash with an interval of ~100ms	Port 1 is on a schedule based on Time of Day.
Steady 2 with flashing dot. The dot will flash with an interval of ~100ms	Port 2 is on a schedule based on Time of Day.
Steady 3 with flashing dot. The dot will flash with an interval of ~100ms	Port 3 is on a schedule based on Time of Day.
Steady 4 with flashing dot. The dot will flash with an interval of ~100ms	Port 4 is on a schedule based on Time of Day.
Steady 5 with flashing dot. The dot will flash with an interval of ~100ms	Port 5 is on a schedule based on Time of Day.
Flashing 1 with the interval of ~100ms	Port 1 is on a countdown timer
Flashing 2 with the interval of ~100ms	Port 2 is on a countdown timer
Flashing 3 with the interval of ~100ms	Port 3 is on a countdown timer
Flashing 4 with the interval of ~100ms	Port 4 is on a countdown timer
Flashing 5 with the interval of ~100ms	Port 5 is on a countdown timer
Blue light is ON	LED Push Button: When Port 1 or 2 is OFF
Green-light is ON	LED Push Button: When Port 2 is ON in manual mode
Green light is Flashing 1 second interval flashing when time remaining is more than 2 minutes otherwise flashes with 0.5 second	LED Push Button: When Port 1 or 2 is ON in Timer or schedular mode
Red light is flashing	LED Push Button: When there is an error with the Swimjet Light (Port 2)

4 Service and Maintenance

Nozzle Adjustment

The BaduStream System is provided with a set of nozzle adjustment tools. These tools will allow the user to set the jet nozzles into position for optimum performance.

When setting the nozzles for basic swimming, it is recommended that you set the nozzles in such a way that each nozzle intersects 4 feet away while breaking the surface at the same time. To help set the nozzles in position for best performance, please follow these instructions:

2 Jet System:

1. Extend the nozzle adjustment tool to full length.
2. Place one nozzle adjustment tool into the center jet nozzle, bring the blue nozzle tool so it is straight out and tilted up, so the end of the tool breaks the surface of the water and leave tool in the jet. (See Figure 16)

3 Jet System:

1. Extend the nozzle adjustment tool to full length.
2. Place one nozzle adjustment tool into the center jet nozzle, bring the blue nozzle tool so it is straight out and tilted up, so the end of the tool breaks the surface of the water and leave tool in the jet. (See Figure 16A)
3. Place the second tool in the left side jet, move the tool so that the end touches the end of the tool left in the center jet where it breaks the surface of the water.
4. Repeat step 3 for the right-side jet using the same tool used on the left jet.

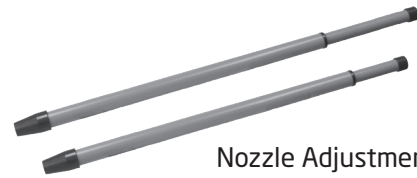

Nozzle Adjustment Tools

NOTE: Though the nozzle adjustment tools are designed for outdoor use, it is advised to protect them from continuous direct heat.

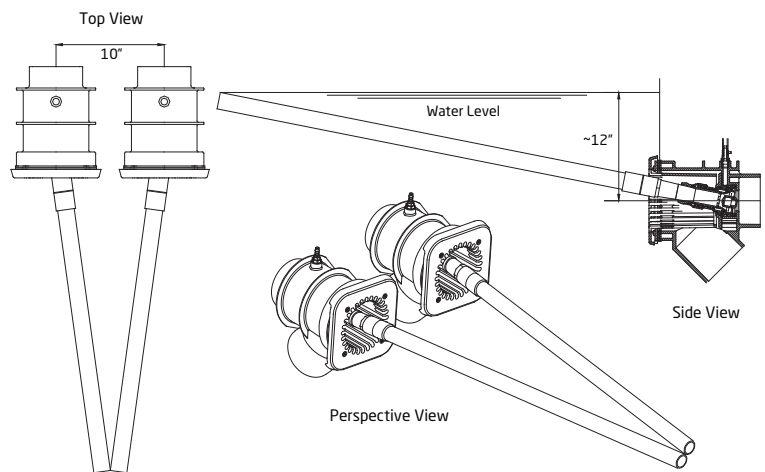

Figure 16
2 Jet System Nozzle Adjustment

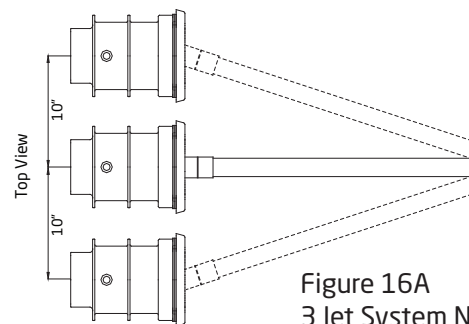

Figure 16A
3 Jet System Nozzle Adjustment

Winterizing

In areas subject to freezing water temperatures, you should protect your equipment. We recommend you purchase a winter cover kit part #2308752006K. This kit includes one (1) winter plate, one (1) gasket and four (4) screws.

Also, you can protect your swimjet system as follows: Drain pool until water level has dropped below the anti-entrapment cover. Then protect pump by removing drain plug and red filler plug (or lid).

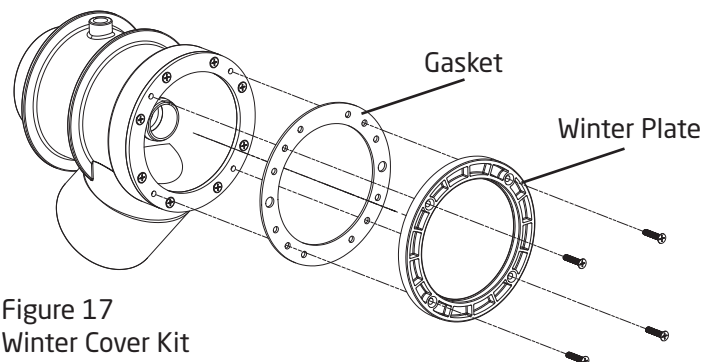

Figure 17
Winter Cover Kit

5 Frequently Asked Questions

How is the current generated?

The pump generates up to 400 GPM coming out of two (2) jet nozzles at 27 ft. per second and 36 ft. per second thru one (1) nozzle creating a swim current in excess of 5700 GPM, measured 6 ft. from the jet.

What size pool do I need?

The BaduStream can be installed in any size pool. However, we recommend a minimum length of 15 ft. and a minimum width of a 8 ft. swimming lane.

What size plumbing is necessary? How far away from the BaduStream can the pump be installed?

Use 4" plumbing up to 30 ft. For runs longer than 30 ft. use 6" plumbing. The pump should be placed as close to the BaduStream as local codes will allow. See plumbing installation on page 8 for more details.

How many amps does the pump operate at?

4.0 HP: Maximum 21.0 - 19.4 amps @ 208-230 V

3.5 HP: Maximum 15.2 - 14.0 amps @ 208-230 V

What size breaker do I need?

You must use a 40 amp breaker for the 4 HP pump or 30 amp breaker for the 3 HP pump to avoid nuisance tripping. A 60 amp breaker is required for three jets and two pumps system.

Is the BaduStream approved?

Yes. The BaduStream swim jet system is listed by MET, UL and complies with UL standard 1563 Swimming Pool Equipment, ASME standard *ANSI/ASME A112.19.8 (ANSI/APSP-16, 2011)* Standard for Swim Jet Combination Fittings, and is VGB 2008 compliant.

Do the covers come in different colors?

Yes. The round covers can be ordered in gray or black. The square cover is only available in black or white.

Does the air regulator come in different colors?

Yes. The air regulator can be ordered in black.

Does it matter if the housing is installed higher or lower than the manual states?

Yes, the center of the jet must be 12" **BELOW** estimated water level for proper performance of unit.

Can the air regulator be placed elsewhere?

Yes, as long as it is not continuously flooded with water.

Can the pump be placed below water level?

Yes. However, for best performance we recommend ordering a pump for flooded suction (Model 21-80/33G) instead of self-priming (Model 21-80/33GS). We recommend installing valves for ease of maintenance.

How far away can the LED push button function properly?

The LED push button will work as far as needed. However, only 50 ft. of cable is provided. Larger runs will require splicing at a junction box or purchasing the 100' cable button.

Do I need to install a motor starter?

In most case, no. All single phase pumps have built-in thermal overloads. Also, the three phase Model 21-80/33 has built-in thermal overload. Other three phase pumps require a motor starter.

Should this be tied into my filter system?

No. The swim jet system and the filter system should not be plumbed together as they each provide very specific functions.

Can I use with automated controls?

Yes. It comes with the ability to tie into automated control systems or other switching devices.

Trouble Shooting

PROBLEM	POSSIBLE CAUSES	SOLUTION
1. Pump will not prime.	<p>a. Suction air leak.</p> <p>b. No water in pump.</p> <p>c. Closed valves or blocked lines.</p> <p>d. Low voltage to motor.</p>	<p>Make sure the red filler plug and o-ring are clean and properly positioned. Tighten red filler plug. Tighten all pipes and fittings on suction side of the pump. Be sure water in the pool is high enough to flow through the jet housing.</p> <p>Make sure pump housing is full of water.</p> <p>Open all valves in system. Open pump and check for clogging of impeller.</p> <p>Check voltage at motor. If low, pump will not come up to speed.</p>
2. Motor does not turn.	<p>a. No power to motor.</p> <p>b. Pump jammed.</p>	<p>Check that all power switches are on. Be sure fuse or circuit breaker is properly set. Check motor wiring at terminals.</p> <p>With power off, turn shaft. It should spin freely. If not, disassemble and repair.</p>
3. Low flow.	<p>a. No water in pump.</p> <p>b. Closed valves or blocked lines.</p> <p>c. Low voltage to motor</p>	See problem 1.
4. Noisy operation of motor.	a. Bad bearings.	Check for noise when shaft is turned by hand. Motor will be very hot in bearing area when running. Replace bearing.
5. Motor runs hot.	These motors will run hot to the touch, however, this is normal. They are designed that way. Thermal overload protector will function to turn them off if there is an overload or high temperature problem. Excessive heat can be caused by:	
	<p>a. Low voltage.</p> <p>b. Installed in direct sun.</p> <p>c. Poor ventilation.</p>	<p>Increase size of electrical wire. Be sure motor is operating on correct voltage.</p> <p>Shield motor from sun's rays.</p> <p>DO NOT block motor ventilation openings.</p>
6. Noisy operation of pump.	<p>a. Air leak in suction line.</p> <p>b. Restricted suction line due to blockage or under size pipe. Indicated by high vacuum reading at pump suction.</p> <p>c. Foreign matter (gravel, metal, etc.) in pump impeller.</p> <p>d. Cavitation.</p>	<p>Repair leak. Check suction pipe, red filler plug, and o-ring (See Problem 1).</p> <p>Remove blockage or increase suction pipe size. Are all suction valves fully open?</p> <p>Disassemble pump and remove foreign matter from impeller.</p> <p>Improve suction conditions. (Reduce suction line length, reduce number of fittings, increase pipe size.)</p>

Trouble Shooting - continued

PROBLEM	POSSIBLE CAUSES	SOLUTION
7. Motor overload protection "kicks out".	a. Motor is not connected properly. b. Low voltage due to under size wire or low incoming voltage. c. Wrong size heaters in protective device. d. Overload due to binding in pump or wrong size impeller.	Check wiring diagram on motor. Check with volt meter. Increase size of supply wire. Report low supply voltage to power company. Voltage at motor must be within 10% of motor nameplate voltage. Heaters should be one size larger than full load amps shown on motor nameplate. Indicated by high amperage readings on motor, binding shaft. Disassemble unit and correct.
8. My ON/OFF LED push button is not working properly?	a. Control Box. b. Wiring.	Check GFCI. If green LED does not stay ON, contact a certified electrician to diagnose control box components. Check the LED push button connections on the control box. Make sure the connections are tight.
9. The system will not turn OFF?	a. Control Box Components.	Press TEST button on the control box GFCI to turn off system. Contact a certified electrician to diagnose control box components.
10. I have adjusted the nozzles but the flow is weak?	a. Debris in pump casing/impeller. b. Improper swim jet assembly.	Check inside pump casing for any debris. The internals may need to be removed for inspection.
11. The plastic cover is cracked.		To order contact the factory at 800-223-8538.

6 Product Specification

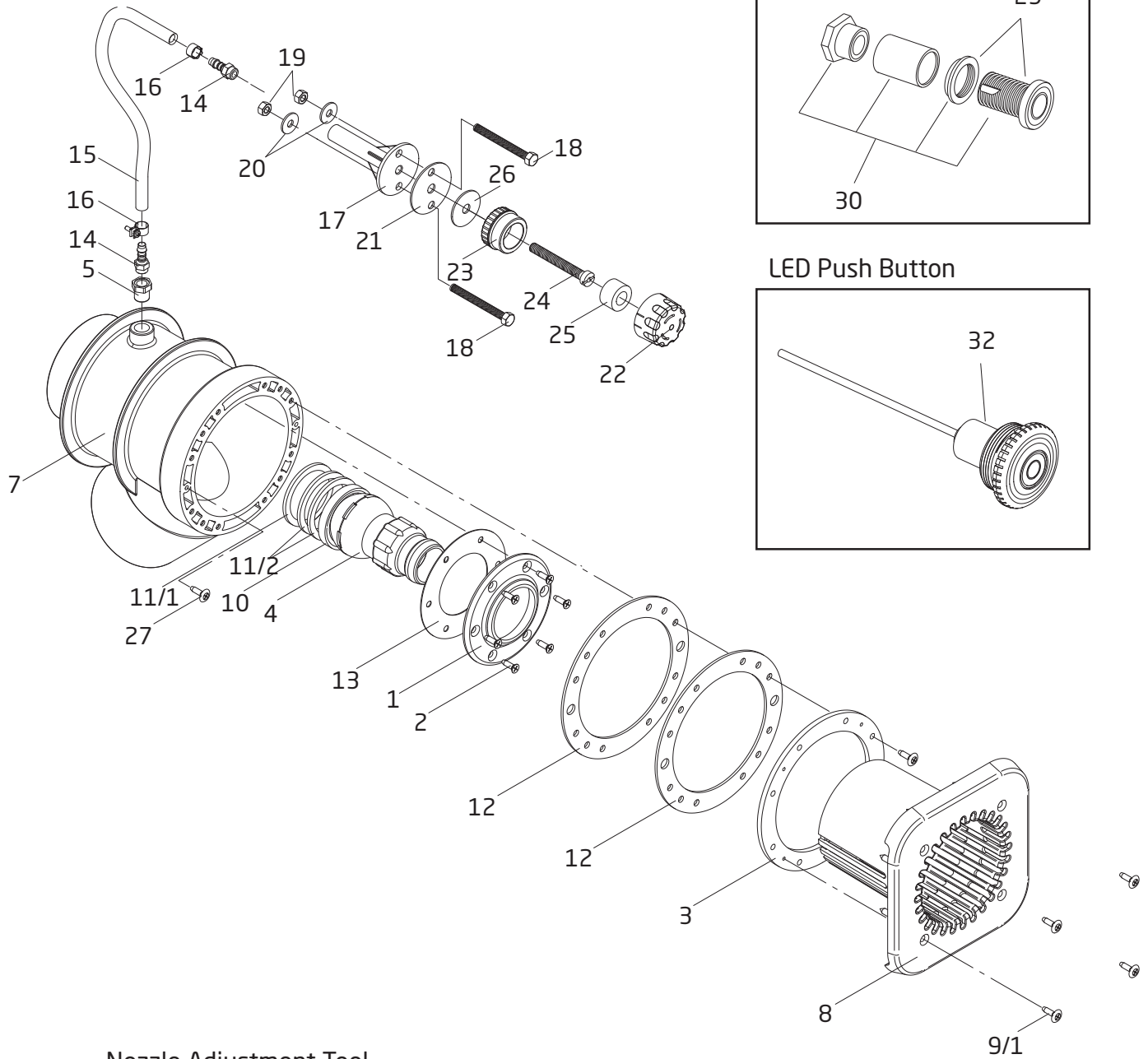

Air Button (prior to Nov. 2019)

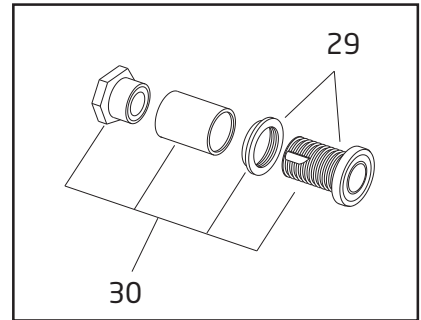

LED Push Button

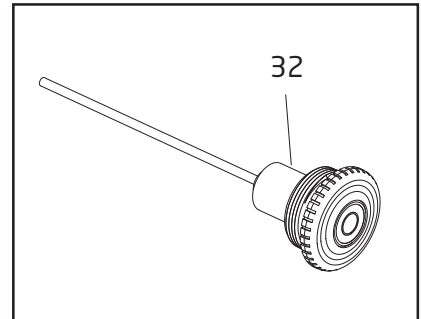

Nozzle Adjustment Tool

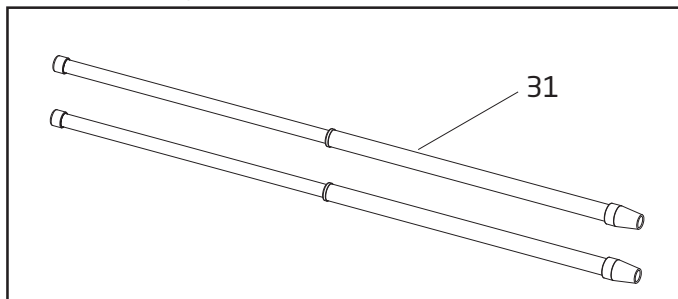

Replacement Parts

Order#	Drawing #	Qty Required	Description
2306002009	1	1	Face Ring - Nozzle
5879006021	2	6	Thread Cutting Screw - Face Ring K60 x 20 A2
2308762004	3	1	Ring - Clamping
2302002857	4	1	Nozzle - Adjustable Flow 40mm
2308761001A	5 & 7	1	Housing w/ Bushing Reducer 16 x 1/4"
2308750003	8	1	Cover - Square White
5879650625	9/1	4	Screw - Square Cover, Phillips/Pan M6 x 25mm
2991000077	9/2	8	Screw - Clamping Ring, Phillips Flat Head M6 x 20mm
5879650625	9/3	8	Screw - Clamping Ring, Phillips/Pan M6 x 25mm
5879650640	9/4	8	Screw - Clamping Ring, Phillips/Pan M6 x 40mm
2991000038	9/5	4	Screw - Sq.cover (Ext. Ring) Slot/Pan M6 x 45mm
2302002056	10	1	Seat - Nozzle
2302002057	11/1	1	Spacer - Nozzle 6.2mm
2302002157	11/2	2	Spacer - Nozzle 4.0mm
2308750005	12	2	Gasket - Clamping Ring
2306002013	13	1	Gasket - Face Ring
2303004000	14-21	1	Holder w/ Hose Subassembly
2301001005	14	2	Nipple - Hose, Air Regulator, Plastic 1/4"
2301001007	15	1	Hose - Air Regulator, Plastic 8 x 3mm (for single or three jet system)
2301004001	15	1	Hose - w/ Y Fitting, Plastic 8 x 3mm (for two jet system)
2301001008	16	2	Clamp - Hose, Air Regulator 14/9 SS A4
2301001009	17	1	Holder - Air Regulator
2991000049	18	2	Screw - Air Holder, Slot/Pan 1/4-20 x 1-1/2"
2991000052	19	2	Nut - Air Holder, Hex Nut 1/4-20 SS
2991400024	20	2	Washer - Air Holder 1/4" SS
2301001013	21	1	Gasket - Air Holder 60 x 11 x 2mm
2301002000	22-26	1	Air Regulator (Sub-Assembly Complete) - White
2301002021	22	1	Top Part - Air Regulator - White
2301002022	23	1	Bottom Part - Air Regulator - White
2301002023	24	1	Screw w/ Hole - Air Regulator, Brass M10 x 80
2301002024	25	1	Ring - Hose, Air Regulator 16 x 30 x 18mm
2301002025	26	1	Gasket - Air Regulator 42 x 11 x 2mm
2991000059	27	2	Thread Cutting Screw - Jet Housing, Phillips/Pan 14 x 1
2304910010	Not Shown	1	Ring - Extension, Jet Housing (Flange)
2336002800A	32	1	50 ft. LED Push Button CPL - Pump

Order#	Drawing #	Qty Required	Description
2920280740	Not Shown	1	Control Box - BJC-7-GFCI-WIFI+CPB
2920280739	Not Shown	1	Control Box - BJC-7-GFCI-P2J3-WIFI+CP

Parts Below Are Unique to the BaduStream Shipped Prior to 11/2019

7400000026	29	1	#10 Air Button
7400000027	Not Shown	1	Air Tube 1/8" x 1' (Price per ft) (50' needed)
7400000062	30	1	Air Button w/ Concrete Adaptor

Optional Parts

2308752006K	Not Shown	1	Winter Cover Kit - Cover, Gasket & 4 Screws
2308750003B	8.1	1	Cover - Square Black
2308760004	Not Shown	1	Cover - Round White
2308760004B	Not Shown	1	Cover - Round Black
2308760004G	Not Shown	1	Cover - Round Gray
2301002000B	22.1 - 26	1	Air Regulator (Sub-Assembly Complete) - Black
2301002029	22.1	1	Top Part - Air Regulator - Black
2301002028	23.1	1	Bottom Part - Air Regulator - Black
2308750006	Not Shown	1	Butterfly Gasket - Clamping Ring
2300022010	Not Shown	1	Cap - Nozzle & Hand Grip, Close Off
2300003010	Not Shown	1	Massage Hose 5 ft. w/Pulsator & Hand Grip
2300003310	Not Shown	1	Massage Hose 15 ft. w/ Pulsator & Hand Grip
2308799007	31	1	Kit - Nozzle Adjustment Tool
2336002800B	32	1	100 ft. LED Push Button CPL - Pump

7 Limited Warranty

Product Registration

Thank you for purchasing a SPECK PUMPS® product please take a few moments to register it online. Your registration helps us keep you up to date on product information and offers.

Before you register:

What do I need to get started?

- The Serial Number and the Model Name
- An email address. We will use this to send you confirmation of your registration.
- A copy of your sales receipt and/or qualified installer's invoice.

To register your SPECK equipment please register online at www.usa.speck-pumps.com/register/

or

Scan QR code to register product



Limited Warranty

Speck Pumps-Pool Products, Inc. grants solely to the original consumer purchaser ("Buyer") of the BADU® SwimJet System(s) the following personal, non-transferable and limited warranty on the following terms and conditions (the "Limited Warranty"): the BADU SwimJet System(s) is warranted to be free of material defects in materials or workmanship under normal use for a period of one (1) year beginning on the date of the Buyer's purchase of the BADU SwimJet System(s) (the "Limited Warranty Period"). Notwithstanding any provisions herein to the contrary, the warranties and obligations hereunder shall not in any event extend for more than two (2) years beyond the date of shipment of the BADU SwimJet System(s) from the factory (the "Limited Warranty Period"). The Limited Warranty is subject to each of the following additional terms and conditions:

1. IN THE EVENT OF ANY BREACH OF THE LIMITED WARRANTY, SPECK PUMPS-POOL PRODUCTS, INC.'S ENTIRE OBLIGATION AND LIABILITY TO BUYER, AND BUYER'S SOLE AND EXCLUSIVE REMEDY SHALL BE AS FOLLOWS: Speck Pumps-Pool Products, Inc. will, at its option, either repair or replace the BADU SwimJet System(s) or refund to Buyer the purchase price actually paid by Buyer for the BADU SwimJet System(s) subject to the Limited Warranty. Speck Pumps-Pool Products, Inc. shall have no obligations under the Limited Warranty unless Buyer delivers timely written notice to Speck Pumps-Pool Products, Inc. of the Limited Warranty claim within the Limited Warranty Period and returns the BADU SwimJet System(s) to Speck Pumps-Pool Products, Inc. if requested. To the fullest extent permitted by law, Speck Pumps-Pool Products, Inc. expressly disclaims any liability for, and the Limited Warranty does not include or cover, any labor, costs or other expenses in connection with the removal, transportation, shipment, insurance, replacement, repair, or installation of repaired or replaced parts or for any other costs or expenses or damages to property or things including, but not limited to, those arising in connection with the use of, or inability to use, the BADU SwimJet System(s).

2. To the fullest extent permitted by law, the Limited Warranty will be void and of no force or effect and Speck Pumps-Pool Products, Inc. will have no liability, responsibilities or obligations to Buyer or with respect to the BADU SwimJet System(s) in the event of the occurrence of any one or more of the following:

- (a) Any damage to the BADU SwimJet System(s) caused by Buyer, any third party, ground movement, other natural forces, acts of God or any other sources or causes not arising from a breach of the Limited Warranty, excluding ordinary wear and tear;
- (b) Any replacement, modification, alteration or repair of any parts or components of the BADU SwimJet System(s) by anyone other than Speck Pumps-Pool Products, Inc.;
- (c) Any abuse, misuse, accident, tampering with, improper installation or modification of the BADU SwimJet System(s) or any other actions, inactions or failures to act that violate the terms and conditions of this Limited Warranty;
- (d) Buyer's failure or inability to present an invoice, bill, receipt or other documentation clearly evidencing that the BADU SwimJet System(s) was installed and maintained in strict compliance with this Limited Warranty and that the claim was timely submitted within the Limited Warranty Period; and/or
- (e) Buyer's failure to comply with the conditions and contingencies set forth in paragraph 3 below.

3. The Limited Warranty is expressly conditioned and contingent upon Buyer's strict compliance with each of the following:

- (a) Installation of the BADU SwimJet System(s) by an experienced and qualified pool industry professional and a licensed electrician who is licensed within the jurisdiction in which the BADU SwimJet System(s) is installed and will be used; and

Limited Warranty - continued

- (b) Buyer's operation and maintenance of the BADU SwimJet System(s) in strict accordance with Speck Pumps-Pool Products, Inc.'s printed operator/maintenance manuals delivered with the BADU SwimJet System(s).

4. DISCLAIMER: THE LIMITED WARRANTY IS THE ONLY WARRANTY MADE AND IS IN LIEU OF ALL OTHER WARRANTIES, AND ANY AND ALL IMPLIED WARRANTY OR CONDITION OF MERCHANTABILITY, THE IMPLIED WARRANTY AGAINST INFRINGEMENT, AND THE IMPLIED WARRANTY OR CONDITION OF FITNESS FOR A PARTICULAR PURPOSE ARE EXPRESSLY LIMITED IN THEIR SCOPE AND DURATION TO THE ONE YEAR TERM OF THE LIMITED WARRANTY SET FORTH HEREIN. SOME STATES DO NOT ALLOW LIMITATIONS ON HOW LONG AN IMPLIED WARRANTY LASTS, SO THE ABOVE LIMITATION MAY NOT APPLY TO THE BUYER.

5. TO THE FULLEST EXTENT PERMITTED BY LAW, IN NO EVENT SHALL SPECK PUMPS-POOL PRODUCTS, INC. OR ITS OFFICERS, DIRECTORS, EMPLOYEES, SHAREHOLDERS, AGENTS, OR REPRESENTATIVES BE LIABLE FOR ANY SPECIAL, INDIRECT, INCIDENTAL, EXEMPLARY OR CONSEQUENTIAL DAMAGES OR LOSS, INCLUDING TIME, MONEY, GOODWILL, AND LOST PROFITS IN ANY WAY WHICH MAY ARISE HEREUNDER OR FROM THE USE OF OR INABILITY TO USE THE BADU SWIMJET SYSTEM(S) OR THE PERFORMANCE OR NONPERFORMANCE OF ANY OBLIGATION UNDER THIS LIMITED WARRANTY. THIS PARAGRAPH, THE WARRANTY DISCLAIMERS IN PARAGRAPH 4 ABOVE, AND THE SOLE AND EXCLUSIVE REMEDY SET FORTH IN PARAGRAPH 1 ABOVE SHALL APPLY EVEN IF SPECK PUMPS-POOL PRODUCTS, INC. HAS BEEN NOTIFIED OF THE POSSIBILITY OR LIKELIHOOD OF SUCH DAMAGES OCCURRING, WHETHER SUCH LIABILITY IS BASED ON CONTRACT, TORT, NEGLIGENCE, STRICT LIABILITY, PRODUCTS LIABILITY OR OTHERWISE, AND EVEN IF ANY REMEDY STATED HEREIN FAILS OF ITS ESSENTIAL PURPOSE. SOME STATES DO NOT ALLOW THE EXCLUSION OR LIMITATION OF SPECIAL, INDIRECT, INCIDENTAL, EXEMPLARY OR CONSEQUENTIAL DAMAGES OR LOSS, SO THE ABOVE EXCLUSIONS AND LIMITATIONS MAY NOT APPLY.

6. This Limited Warranty gives the Buyer specific legal rights, and the Buyer may also have other rights, which vary from state to state.

7. A return merchandise authorization ("RMA") must be obtained from Speck Pumps-Pool Products, Inc. before returning any product. Products returned without an RMA will be refused and returned, unopened, to the Buyer. All returned products are to be sent freight prepaid and insured for Buyer's protection to the manufacturer at 8125 Bayberry Road, Jacksonville, Florida 32256 USA. Under no condition will products be accepted after the expiration of the Limited Warranty Period. Speck Pumps-Pool Products, Inc. shall not bear any costs or risks incurred by Buyer in shipping a defective BADU SwimJet System(s) to Speck Pumps-Pool Products, Inc. or in shipping a repaired or replaced BADU SwimJet System(s) to Buyer.

